



CAN-Repeater
CRep N-.../S24/RMD
User Manual

EMS Sonnenhang 3
D-85304 Ilmmünster
Tel +49-8441/490260
THOMAS WÜNSCHE Fax +49-8441/81860

Documentation for CAN-Repeater CRep N-.../S24/RMD.

Document version: V1.3

Documentation date: May 23th, 2005

No part of this document or the software described herein may be reproduced in any form without prior written agreement from EMS Dr. Thomas Wünsche.

For technical assistance please contact:

EMS Dr. Thomas Wünsche
Sonnenhang 3

D-85304 Ilmmünster

Tel. +49-8441- 490260

Fax +49-8441- 81860

Email: support@ems-wuensche.com

Our products are continuously improved. Due to this fact specifications may be changed at any time and without announcement.

WARNING: CRep N-.../S24/RMD hardware and software may not be used in applications where damage to life, health or private property may result from failures in or caused by these components.

Contents

1 Overview	1
1.1 Attributes	1
1.2 General Description	1
1.3 Ordering Information	2
2 Electrical Characteristics	3
2.1 Absolute Limiting Values	3
2.2 Nominal Values	3
3 Operating Instructions.	4
3.1 Layout and Pin Assignment	4
3.2 Block Diagram	6
4 Measurements	7
5 Appendix A: Topology examples	8

1 Overview

1.1 Attributes

- Protocol transparent CAN repeater
- High throughput due to low latency
- ISO 11898 compatible bus interface
- Shutdown of erroneous bus segments
- Rail mountable

1.2 General Description

The compact CAN repeater CRep N transmits and amplifies signals transparent to the CAN protocol. Each of the two CAN connections has the physical behaviour of a single bus node. CRep N permits a flexible design of the network topology. Star and tree structures can be implemented as well as long stub lines. Through the possibility to use the network structure that fits the application best a reduction of installation costs can be reached.

The maximum data rate in CAN networks, depending on signal propagation delays, can be increased if CRep N is used to improve the network structure. An increase of the maximum node count in a CAN network can be reached by splitting the network in subnets that are connected by CRep N. Each subnet can include the number of CAN nodes permitted by the drivers output current. Where CAN signals have to be transmitted over long distances, CRep N can be used for signal conditioning. The integrated shut down capability in case of errors reduces the impact on intact bus segments by defective segments for the most commonly occurring errors.

1.3 Ordering Information

12-01-0xx-20	CRep N-.../S24/RMD CAN-Repeater for rail mounting, extended temperature range (... Inhibit time)
--------------	--

2 Electrical Characteristics

2.1 Absolute Limiting Values

Any (also temporary) stress in excess of the limiting values may cause permanent damage on CRep N-.../S24/RMD and connected devices.

Parameter	Min	Max	Unit
Storage temperature	-40	+90	°C
Operating temperature	-20	+80	°C
Power supply voltage	-100	+35	V
Voltage on signal lines	-30	+30	V
Maximum power dissipation (at 60°C)	–	1000	mW

2.2 Nominal values

All values, unless otherwise specified, refer to a supply voltage of 24V and an environmental temperature of 20°C.

Parameter	Min	Typ	Max	Unit
Current consumption ¹ (no load)	–	25	–	mA
Current consumption ¹ (250kBit/s, 100% load)	–	35	–	mA
Power supply voltage	11	24	30	V
Propagation delay	–	100	175	ns

¹ with 24V supply voltage

3 Operating Instructions

3.1 Layout and Pin Assignment

CRepN devices include 2 CAN segments, wired by a terminal block with 8 clamps. Besides the CAN signals the terminal block also carries the power supply for CRepN.

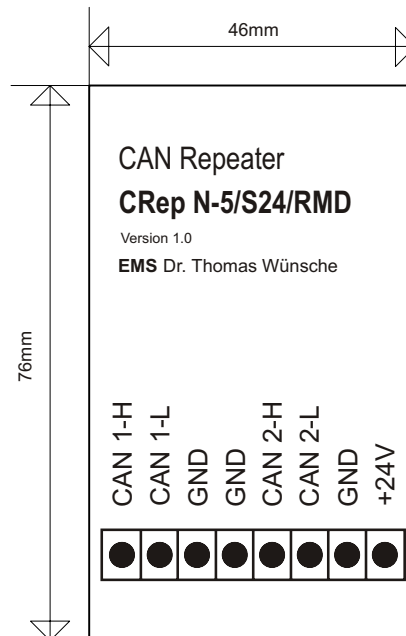

The following table shows the terminal assignment:

Pin	Name	Function
1	CAN1-H	CAN1-High bus line
2	CAN1-L	CAN1-Low bus line
3	GND	Ground
4	GND	Ground
5	CAN2-H	CAN2-High bus line
6	CAN2-L	CAN2-Low bus line
7	GND	Ground
8	+24V	24V power supply

4 Measurements

All values in [mm].

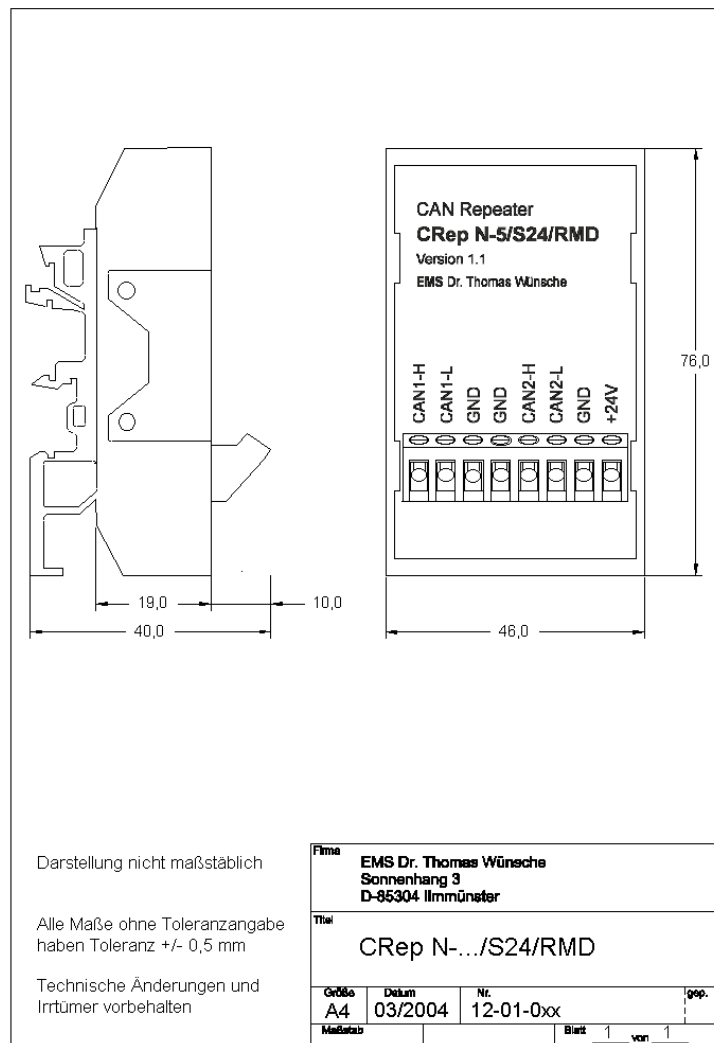

5 Appendix A: Topology examples

CAN busses should always be terminated on both ends, typically using a 120Ohm termination resistor between CAN-High and CAN-Low signal lines.

Legend



Line topology with repeaters

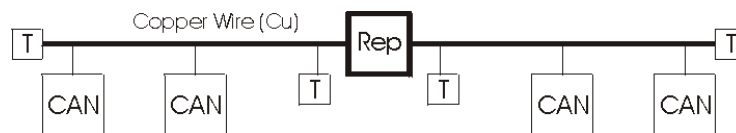

Tree topology with repeaters

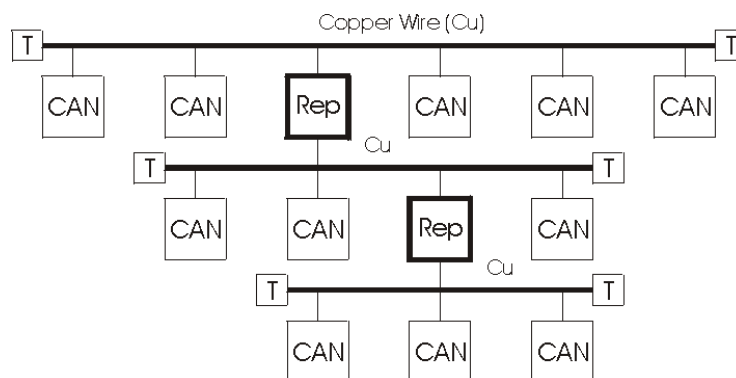

Star topology with repeaters

